



IRADiON

Ceramic Core CO₂ Lasers

OPERATOR'S MANUAL

Eternity Series

CO₂ Laser: Models E25, E30 & E40



Table of Contents

| | |
|---|-----------|
| Table of Contents | 2 |
| Hazard Information | 3 |
| Terms | 3 |
| General Hazards | 3 |
| General Hazards | 4 |
| Other Hazards | 4 |
| Label Locations | 5 |
| Laser Safety | 6 |
| Declaration of Conformity | 7 |
| Declaration of Conformity | 8 |
| Introduction | 9 |
| CDRH | 9 |
| Available Safety Features | 9 |
| System Overview | 10 |
| Quick Start Connection Guide | 11 |
| 1. Power Cable, All Lasers | 11 |
| 2. Serial Communication Connector (3.5mm Jack)..... | 11 |
| 3. Connector (DB-9) | 12 |
| Nominal Operating Voltages..... | 13 |
| “F” Type Lasers | 13 |
| Operation of Unit | 14 |
| Tickle Pulse | 15 |
| Laser Command Signals | 15 |
| System Test | 16 |
| Laser Indicator Lights | 16 |
| Mechanical Outline | 17 |
| Troubleshooting | 19 |
| Indicator Lights Details | 19 |

Hazard Information

Hazard information includes terms, symbols, and instructions used in this manual, or on the equipment, to alert both operating and service personnel to the recommended precautions in the care, use, and handling of Class 4 laser equipment.

Terms

Certain terms are used throughout the manual or on the equipment labels. Please familiarize yourself with their definitions and significance.



Danger

Imminent hazards which, if not avoided, will result in death or serious injury.



Warning

Potential hazards which, if not avoided, could result in death or serious injury.



Caution

Potential hazards or unsafe practices which, if not avoided, may result in minor or moderate injury.

General Hazards



Danger – Serious Personal Injury

This Class 4 laser product emits invisible infrared laser radiation at 10.6µm.

Do not allow laser radiation to enter the eye by viewing direct or reflected laser energy. CO₂ laser radiation can be reflected from metallic objects even though the surface is darkened. Direct or diffuse laser radiation can inflict severe corneal injuries leading to permanent eye damage or blindness. All personnel must wear eye protection suitable for 10.6µm CO₂ radiation when in the same area as an exposed laser beam. Eyewear protects against scattered energy but is not intended to protect against direct viewing of the beam.

Never look directly into the laser output aperture or view scattered laser reflections from metallic surfaces.

Enclose the beam path whenever possible. Exposure to direct or diffuse CO₂ laser radiation can seriously burn human or animal tissue, which may cause permanent damage.

This product is not intended for use in explosive, or potentially explosive, atmospheres.

General Hazards



Warning – Serious Personal Injury

U.S. customers should refer to and follow the laser safety precaution described in the American Nation Standards Institute (ANSI) Z136.1-2007 document, Safe Use of Lasers. Procedures listed in this Standard include the appointment of a Laser Safety Officer (LSO), operation of the product in an area of limited access by trained personnel, servicing of equipment only by trained and authorized personnel, and posting of signs warning of the potential hazards.

European customers should appoint a Laser Safety Officer (LSO) who should refer to and follow the laser safety precautions described in EN60825.1-2007, Safety of Laser Products.



Warning – Serious Personal Injury

Materials processing with a laser can generate air contaminates such as vapors, fumes, and/or particles that may be noxious, toxic, or even fatal. Material Safety Data Sheets (MSDS) for materials being processed should be thoroughly evaluated and the adequacy of provisions for fume extraction, filtering, and venting should be carefully considered. Review the following reference for further information: ANSI Z136.1-2007, Safe Use of Lasers.



Warning – Serious Personal Injury

Te use of controls or adjustments, or performance of procedures other than those specified herein, may result in hazardous radiation exposure.

Other Hazards

The following hazards are typical for this product family when incorporated for intended use: (A) risk of injury when lifting or moving the unit; (B) risk of exposure to hazardous laser energy through unauthorized removal of access panels, doors, or protective barriers; (C) risk of exposure to hazardous laser energy and injury due to failure of personnel to use proper eye protection and/or failure to adhere to applicable laser safety procedures; (D) risk of exposure to hazardous or lethal voltages through unauthorized removal of covers, doors, or access panels; (E) risk of exposure and/or interference from radio-frequency (RF) electro-magnetic energy through unauthorized removal of covers, doors, or access panels; (F) generation of hazardous air contaminants that may be noxious, toxic, or even fatal.

Label Locations

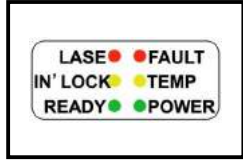

IRADIION AND THE IRADIION INFORMATION LOGO ARE TRADEMARKS OF IRADIION LASER, INC. THE DESIGN OF THIS INFORMATION LOGO IS THE PROPERTY OF IRADIION LASER, INC. THE DESIGN OF THIS INFORMATION LOGO IS NOT TO BE REPRODUCED OR TRANSMITTED IN ANY FORM OR BY ANY MEANS, ELECTRONIC, MECHANICAL, PHOTOCOPYING, RECORDING, OR BY ANY INFORMATION STORAGE AND RETRIEVAL SYSTEM. THE PRODUCT'S EXACT COLOR SCHEME MUST BE DEFINED BY THE FINAL DESIGN FROM IRADIION LASER, INC.

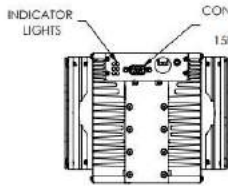
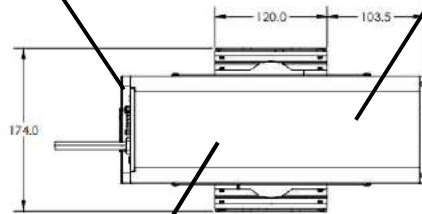

CONTROL INPUT/OUTPUT STANDARD: 15PIN, 9 PIN OR RJ45

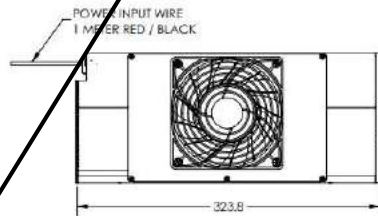

POWER INPUT WIRE 1 METER RED / BLACK

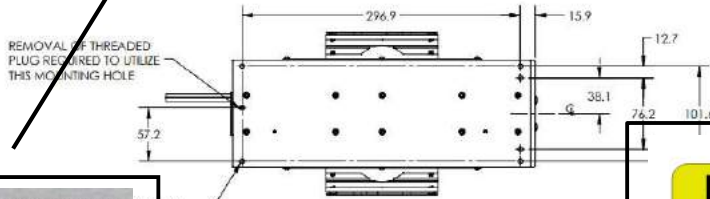
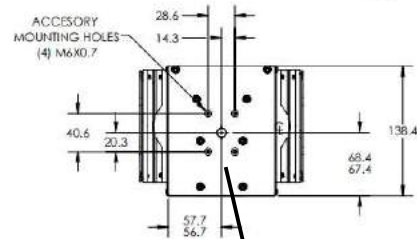

REMOVAL OF THREADED PLUG REQUIRED TO UTILIZE THIS MOUNTING HOLE



This laser is for use as a component only. It does not comply with standards for complete laser products specified by 21 CFR 1040 or EN 60825-1:2014

Model# E40
 Serial # 65B30234203D

Input Power: 48V – 15A
 Output wavelength: 10.6µm
 Mfg Date: 07/11/2022

IRADION
 Ceramic Core CO₂ Lasers

Iradiion Laser, Inc.
 1 Technology Drive
 Uxbridge, MA. 01569
 Manufactured under one or more U.S. Patents 8,422,528, 7,460,577, 8,295,319 and other U.S. and/or International Patents Pending.

Laser Safety

To prevent exposure to direct or scattered laser radiation, follow all safety precautions specified throughout this manual and exercise safe operating practices per ANSI Z136.1-2007 at all times when actively lasing.

Always wear approved Laser Safety Glasses with a minimum OD (Optical Density) 4.27 for a wavelength of 10.6µm.

A CO₂ laser is capable of igniting most materials under the proper conditions. Never operate the laser in the presence of flammable or explosive materials, gases, liquids, or vapors.

| |
|--|
| IEC 60825-1 MPE (Maximum Permissible Exposure) = 1.00e-1 NOHD (Nominal Ocular Hazard Distance) = 4.51e+2 |
|--|

****NOTICE****

The output aperture comes covered by a clearly marked dust guard that must be removed before use. Firing the laser through the cover **WILL** cause permanent destruction of the laser.



Declaration of Conformity

When integrating Iradion's Infinity Series Lasers, the Buyer and/or integrator of the end system is responsible for meeting all applicable Standards to obtain the CE mark. To aid in this compliance process, Iradion's testing program has demonstrated that Infinity-Series lasers comply with the relevant requirements of 2014/30/EU, the Electromagnetic Compatibility Directive, as summarized in the table below.

Table 1. European Union Directives.

| Applicable Standards / Norms | |
|------------------------------|--|
| 2014/30/EU | Electromagnetic Compatibility Directive |
| 2006/95/EC | Low Voltage Directive |
| 2015/836/EU | RoHS Directive |
| EN 61010-1-2010 | Safety Requirements for Electrical Equipment for Measurement, Control, and Laboratory Use - Part 1: General Requirements |
| EN 61000-6-4:2007 | Radiated Emissions Group 1, Class A |
| EN 61000-6-4:2007 | Conducted Emissions Group 1, Class A |
| EN 61000-6-2:2005 | Electrostatic Discharge Immunity |
| EN 61000-6-2:2005 | RF Electromagnetic Field Immunity |
| EN 61000-6-2:2005 | Electrical Fast Transient/Burst Immunity |
| EN 61000-6-2:2005 | Conducted RF Disturbances Immunity |

After a laser or laser processing system has met the requirements of all applicable EU Directives, the product can bear the official compliance mark of the European Union as a Declaration of Conformity.

After a laser or laser processing system has met the requirements of all applicable EU Directives, the product can bear the official compliance mark of the European Union as shown in the figure below and a Declaration of Conformity is provided for the compliant component.

Declaration of Conformity

in accordance with ISO / IEC 17050-2:2010

Manufacturer's Name: Iradion Laser, Inc.,
Manufacturer's One Technology Drive
Address: Uxbridge, MA 01569 U.S.A.

Hereby declare under our sole responsibility that the following equipment:

Product Name: Eternity Series
Model Number: E25, E30 & E40

Conforms to the following Directive(s) and Standard(s):

Applicable Directive(s):

2014/30/EU Electromagnetic Compatibility Directive

2014/35/EU Low Voltage Directive

2011/65/EU RoHS Directive

Applicable Standard(s):

EN 61010-1:2010 Safety Requirements for Electrical Equipment for Measurement,
Control, and Laboratory Use - Part 1: General Requirements

EN 60825-1-2:2007 Safety of Laser Products

EN 61000-6-4:2007 Radiated Emissions, Group 1, Class A

EN 61000-6-4:2007 Conducted Emissions, Group 1, Class A

EN 61000-6-2:2005 Electrostatic Discharge Immunity

EN 61000-6-2:2005 RF Electronic Fields Immunity

EN 61000-6-2:2005 Electrical Fast Transient/Burst Immunity

EN 61000-6-2:2005 Conducted RF Disturbances Immunity

*Lasers are not subject to EN 60825-1:2014, *Safety of Laser Products*. Buyers of laser products are solely responsible for meeting applicable Directives and Standards for CE compliance and marking, since the final product will itself be subject to this standard.

Corporate Officer:



Philippe Brak, President/CEO



Date: 7/30/2020

Introduction

This guide provides the basic information needed to operate an Iradion Laser. This laser is designed for use while integrated within a system and is **not designed to meet CDRH requirements as a stand-alone product**. As such, the user must be aware of certain requirements before use.

CDRH

This is an OEM laser component that has been designed for integration into a functioning laser system. As a stand-alone device, it cannot be turned on and therefore does not incorporate all of the safety features required by the Center for Devices and Radiological Health (CDRH). Provisions for the incorporation of these safety features are available, and it is expected that the user will apply them and fully comply with all CDRH requirements.

Available Safety Features

The following safety features are available as electronic signals on the laser's HD-15 control connector:

| | |
|--------------------------|--|
| <i>Interlock</i> | <i>Upon contact closure, allows the system to operate. An open connection will disallow the laser from firing.</i> |
| <i>Key switch</i> | <i>Upon contact closure, allows the laser to fire after imposing a 5-second delay. (Key switch function is program version dependent.)</i> |
| <i>Power up in Fault</i> | <i>Requires the key switch to be cycled. (Program version dependent.)</i> |
| <i>Lase signal</i> | <i>Output signal indicating the laser is firing.</i> |
| <i>Fault signal</i> | <i>Output signal indicating the malfunction of an internal component or the electronics.</i> |
| <i>Indicator lights</i> | <i>DC Power, Temp Warning, Interlock, Fault, Ready, Lase</i> |

System Overview

Iradion CO₂ lasers are available in the following rated wattages: 23, 30 & 40 Watts. Each model has a maximum power output that exceeds their rated wattages, and all models feature identical footprints, so they all integrate RFPA and cooling in one package. Two connectors in the rear provide the interface to control signals, power, and returns diagnostic signals and faults signals. Connector pins and associated electronics are protected against static ESD damage. DC power is applied to the one-meter power cord.



Caution

There are no user-serviceable parts under the cover. The RF cover must be removed according to procedure; otherwise, damage could occur. The RF cover edges are RF sealed to the top heat sink, which makes it very difficult to slide off the cover. The laser may not operate properly without the cover in place. There are dangerous RF voltages under the cover that will cause serious RF burns to the skin if touched.



Caution

The lasers are waveguide lasers with a “slab” unstable optical resonator. The resulting elliptical beam is corrected by a cylindrical lens in the black extension tube mounted to the faceplate. This assembly is exactly positioned so that the beam direction is close to the original elliptical beam. Removal of the cylindrical lens assembly will result in the loss of this original alignment and will require a procedure for replacement.



Caution

The optical intensity at the cylindrical lens is **VERY** high (>6000W/cm²). Any contamination to the optical surface could cause runaway destruction of the lens. Do **NOT** burn materials close to the lens or leave fingerprints on the lens.

Quick Start Connection Guide

The D-Sub 9 connector contains all the available connections for laser operation. The 3.5 mm Stereo Jack connector can be used for serial communications.

1. Power Cable, All Lasers

| Designation | Pin | Description | Comment |
|-------------|-----|-------------------------------|--------------------------------------|
| Black | - | Power Ground | 12-gauge wire to power supply Ground |
| Red | - | Power VDC positive connection | 12-gauge wire to power supply |

2. Serial Communication Connector (3.5mm Jack)

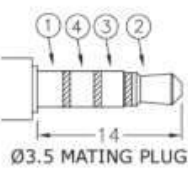
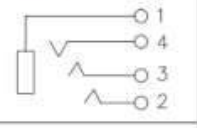
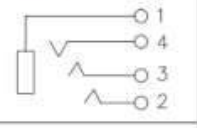
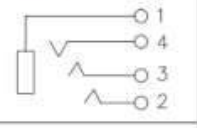
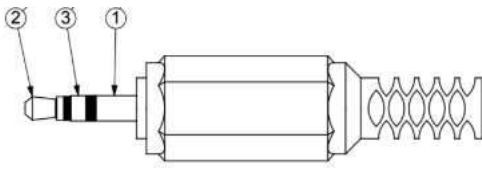
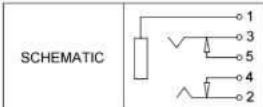
| Serial Connector | | | | | | | | | | | | | | | |
|---|--|-----------|-------------|-----------|--|-----|--|---|--------|---|-----|---|--------|---|--------|
| Connector Model – CUI Inc, SJ1-43502PM, Or Equivalent | | | | | | | | | | | | | | | |
| Pin | Signal | | | | | | | | | | | | | | |
| 1 | Ground | | | | | | | | | | | | | | |
| 2 | TX, Transmit | | | | | | | | | | | | | | |
| 3 | RX, Receive | | | | | | | | | | | | | | |
| 4 | NC, No Connection | | | | | | | | | | | | | | |
| Mating Plug, 4-Wire (For Reference Only) | | | | | | | | | | | | | | | |
| Connector Model, CUI Inc, SP35401, Or Equivalent | | | | | | | | | | | | | | | |
|  <p>Ø3.5 MATING PLUG</p> | <table border="1" style="border-collapse: collapse;"> <tr> <td>Model No.</td> <td>SJ1-43502PM</td> </tr> <tr> <td>Schematic</td> <td></td> </tr> <tr> <td>PIN</td> <td></td> </tr> <tr> <td>1</td> <td>sleeve</td> </tr> <tr> <td>2</td> <td>tip</td> </tr> <tr> <td>3</td> <td>ring 1</td> </tr> <tr> <td>4</td> <td>ring 2</td> </tr> </table> | Model No. | SJ1-43502PM | Schematic |  | PIN | | 1 | sleeve | 2 | tip | 3 | ring 1 | 4 | ring 2 |
| Model No. | SJ1-43502PM | | | | | | | | | | | | | | |
| Schematic |  | | | | | | | | | | | | | | |
| PIN | | | | | | | | | | | | | | | |
| 1 | sleeve | | | | | | | | | | | | | | |
| 2 | tip | | | | | | | | | | | | | | |
| 3 | ring 1 | | | | | | | | | | | | | | |
| 4 | ring 2 | | | | | | | | | | | | | | |
| Mating Plug, 3-Wire (For Reference Only) | | | | | | | | | | | | | | | |
|  | | | | | | | | | | | | | | | |
| TYPICAL STEREO JACK SCHEMATIC* | | | | | | | | | | | | | | | |
|  | <p>S - SLEEVE R - RING T - TIP</p> | | | | | | | | | | | | | | |

3. Connector (DB-9)

NOTE: The use of standard cables with a DB-9 pin connector is not permitted when interfacing to this connector.

| Control Interface Signals | | |
|---|----------------------------|--|
| Connector D-Sub 9 female w/ threaded standoffs, industrial grade. | | |
| Pin | Name | Description |
| 1 | Modulation High Input | +5V TTL PWM, Laser Power Control, Positive |
| 2 | Laser Ready Out | +5V @ 20 mA Typical, 40 mA Maximum |
| 3 | Lase Indicator Out | +5V @ 20 mA Typical, 40 mA Maximum |
| 4 | Over Temperature Fault Out | +5V @ 20 mA Typical, 40 mA Maximum |
| 5 | DC (+5V) Out | Accessory Power. 250 mA Maximum |
| 6 | Modulation Low Input | Ground (factory configuration). Optionally, the signal can be optically isolated. Please refer to Iradion document 92-3006, RS232 Operation Manual for information on optional ground isolation. |
| 7 | DC Voltage Fault Out | +5V @ 20 mA Typical, 40 mA Maximum |
| 8 | GND | Ground |
| 9 | Laser Enable In | 5 VDC required to enable the laser |

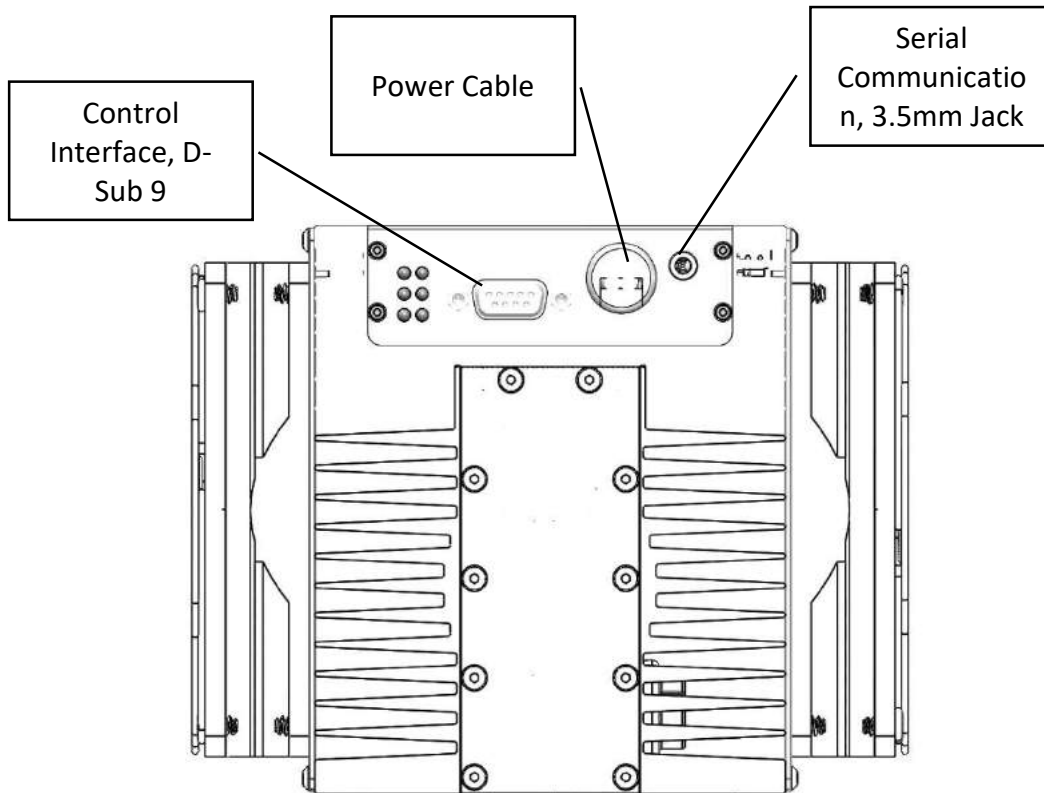

*The laser may be modulated at up to 140 KHz.



Caution

This unit is provided with a 1-meter length of cable for DC power. If the wire is extended in length, #10 wire must be used. Do not add more than 1-meter additional wire unless it is heavier than #10. Power supply regulation should be greater than $\pm 2\%$ and ripple no greater than 400 mV. No damage can occur to the laser if the DC voltage is in the range of 0 to 50 Volts; however, the laser will only operate at the specified voltage. Check your power supply before attachment and adjust it to the **specified voltage**. The software will not allow more than -2/+1.5 Volts variation including line drops at high current settings. **If output becomes intermittent and the fault light flashes on and off, the voltage drop on the power cable may be too large or the power supply may be bad. If the fault light lights up on power up, check the power supply voltage setting.**

Nominal Operating Voltages

| | | | |
|----------------------|-----|-----|-----|
| Model Number: | E25 | E30 | E40 |
| DC Voltage: | 48V | 48V | 48V |

“F” Type Lasers

Current production lasers with fan-cooling are marked E25, E30 & E40. These lasers are designed to control fan operation internally based on the operating temperature. The fan will start operating at 32°C or higher and will stop at 30°C or lower. This fan function is enabled via commands sent over the RS 232 lines. If the fans do not start when power is applied, this means that the fan function is disabled. If fans do not start with power up, this does not indicate fan malfunction! Factory fresh lasers are always shipped with the fan function disabled. See the Iradion LCC Comm Protocol_v1.5 for information on communicating with the laser control card.

Operation of Unit

1. Mount the laser in a manner such that the beam will strike a target capable of absorbing up to 80 Watts of power. Make sure that the airflow openings are clear of any obstructions.
2. Confirm that the signal connections to the laser are secure and tight. Make sure that the power supply is correctly adjusted and is capable of delivering a minimum of the rated amps plus 2 amps margin.
3. Connect the laser power leads to DC, Red + using at least 10-gauge wire. The power supply can affect laser performance! Use a high-quality, well-regulated supply.
4. Power up the DC supply. The fans should start. (The "F" fan option, when programed, will not start the fans until the laser reaches a preset temperature.)
5. Make sure the "INTERLOCK" switch is down or off, or the interlock line is ungrounded.
6. The Key Switch line must be toggled from off to on to arm the laser. If the switch is closed when power is applied, turn it off and then on. There will be a 6 second delay before the green "READY" light lights up. **(This switch must be toggled to arm the system after power up.) NOTE: This function depends on the software version and programing. OEM lasers are shipped without this function.**
7. When the system arms to "READY", if the tickle is being applied, the "LASE" light should also light up when the interlock is enabled. The "LASE" light will get brighter as the power increases; this is normal.
8. The "Mod Hi" connection to the laser requires that the command signal contain a tickle pulse of 1 to 3 μ S at 5,000 Hz when the laser is not being commanded to fire. Tickle rates of greater than 5,000 Hz will result in dangerous conditions (possible unexpected low-level emissions). When the laser is being commanded, the modulation rate can reach up to 200 KHz. **NOTE: OEM lasers may be shipped with the tickle function disabled. In this case, the user must provide the correct tickle protocol at all times.**
9. Make sure there is enough cool air available to dump the heat! Do not obstruct the air flow in any way or modify the fans. The laser should not be near heaters or other heat sources that increase the ambient fan inlet temperature.

Tickle Pulse

This option is supplied by the customer, Iradion **DOES NOT** supply the tickle pulse inside the laser.

Laser Command Signals

During laser bench testing, it is recommended that command signals be generated from an Iradion Laser Controller or properly programed pulse generator. These units can provide the tickle pulse and drive signals needed to test and operate the laser properly. Alternatively, most motion control software packages are designed to provide the proper pulse protocol.

The Modulation pins on both the “D” connector, **pins 1 (high) and 6 (low)** and the RJ-45, **pins 1 (high) and 6 (low)** are designed to allow either *floating* or *grounded* input modes.

Both the High and Low pins should be used in either case. A software setting made through the RS232 interface will either ground Modulation Low or leave it floating. **Factory setting is set to ground Modulation Low.**

It is possible to use the Modulation High pin only if the Modulation Low pin is grounded by software settings or by a physical wire; however, depending on the ground integrity of the host system and level of ground noise this may not be the best solution.

The diagram below shows the circuit of the modulation input interface:

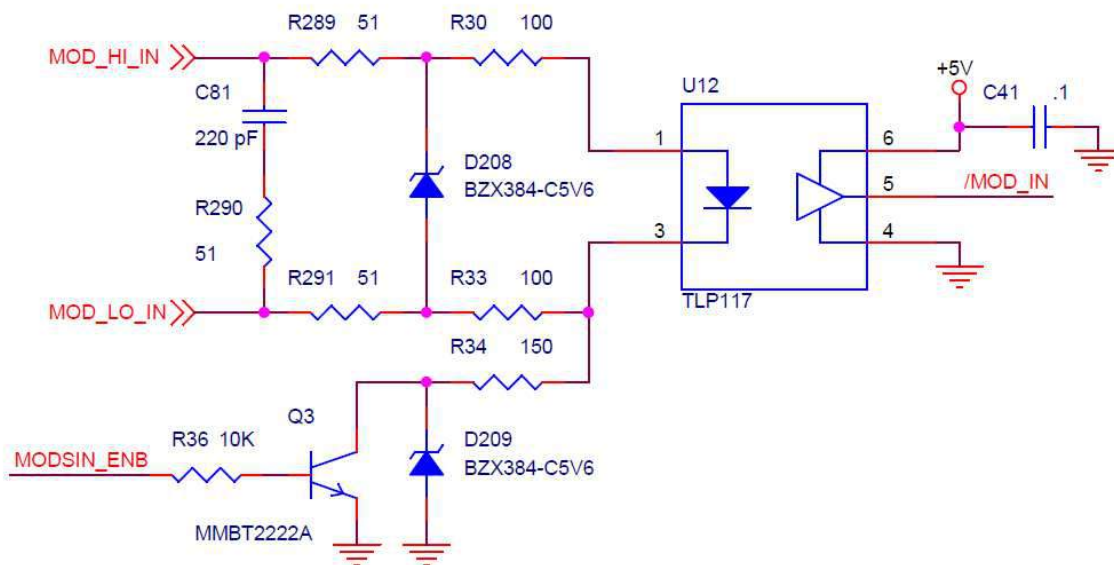

System Test

The operation of the laser is possible after the above connections are completed. To test the laser, apply power and the tickle command signal. If the software settings require a key switch, toggle it off and on. After about 6 seconds, the system will be armed.

The interlock connections must be closed to operate the system.

Fault conditions can be detected by viewing the LED indicators on the rear of the laser. The signals monitored with LEDs are:

| | |
|--------------------|---|
| LASER READY | Lights up when the laser controller is ready for operation. |
| OVERTEMP | Lights up when the RFPA is getting too hot. Faults at Temp limit. |
| FAULT | Lights up when the controller is in a Fault state. |
| LASE LED | Lights up whenever signals are delivered to the RFPA FET bias. |
| POWER | Lights up whenever DC power is applied. |
| INTERLOCK | Lights up when the interlock switch is closed. |

Laser Indicator Lights

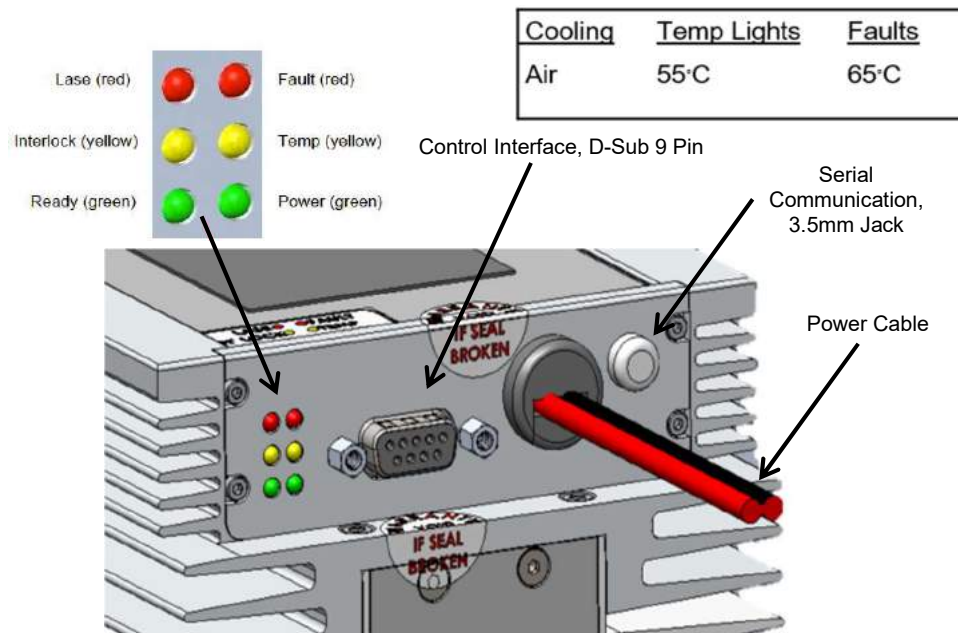

Mechanical Outline

Specifications: 9.3 μm, 10.2 μm and 10.6 μm

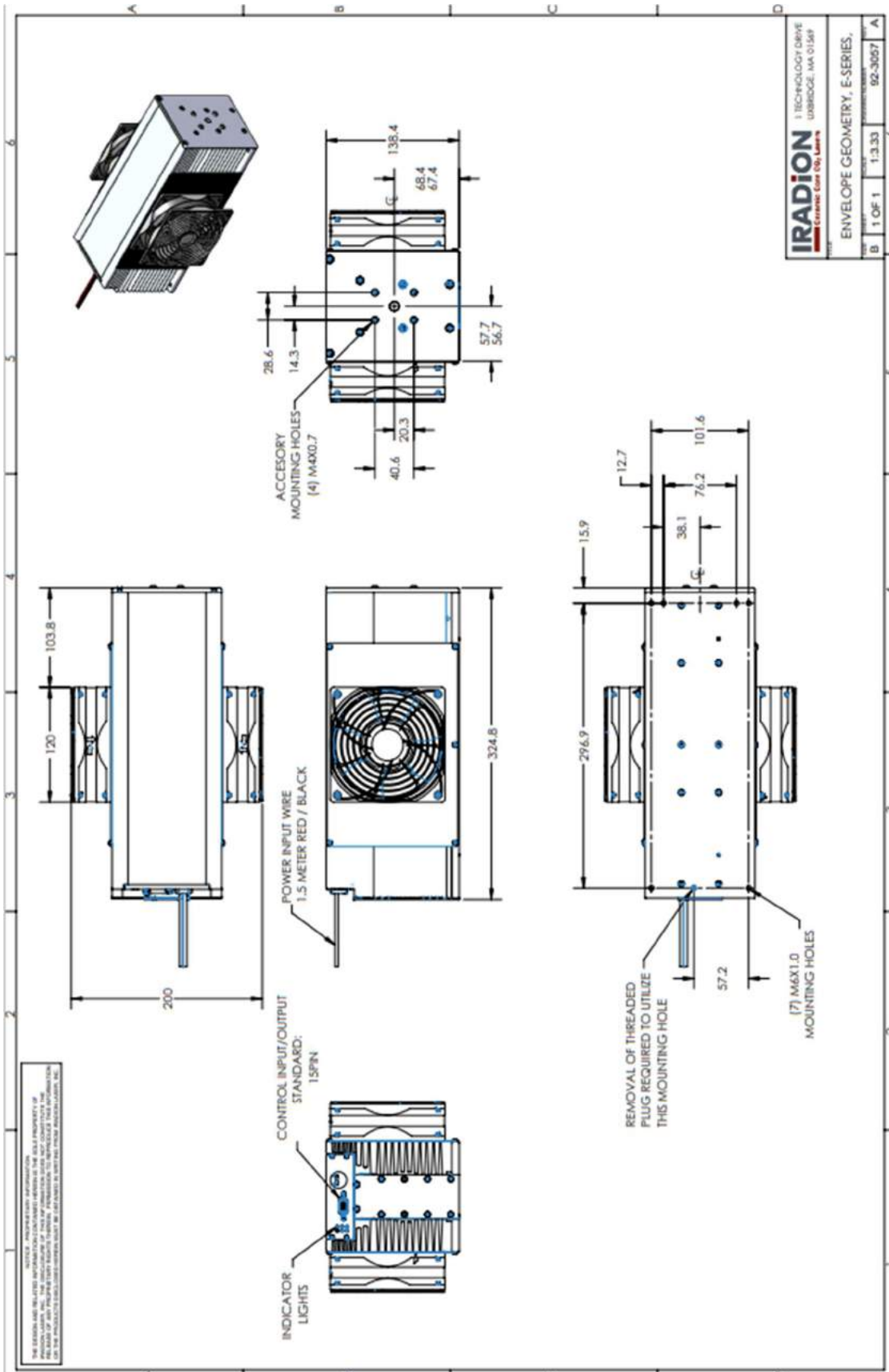



IRADION

Ceramic Core CO₂ Lasers

ETERNITY SERIES

CERAMIC CO₂ LASER

Iradion **Eternity Series** patented laser design hermetically seals the CO₂ laser gas in a monolithic ceramic core resonator, and energizes it with the latest RF electronics. The compact, integrated package achieves exceptional performance and long-term reliability.

SPECIFICATIONS:

| Model Eternity | E25 | E30 | E40 |
|---|-----------------------|------------|------------|
| Rated Optical Power (W) | 25 | 30 | 40 |
| Mode Quality (M ²) | ≤ 1.2 | | |
| Beam Ellipticity | < 1.2:1 | | |
| Beam Diameter (mm), 1/e ² @ 0m | 2.5 ± 0.5 | | |
| Beam Divergence (mrad, Full angle) | < 7 | | |
| Wavelength (µm) | 9.3 | 10.2, 10.6 | 10.2, 10.6 |
| Rise Time (µs) | < 90 | | |
| Power Stability, Fan | < ± 5% | | |
| Polarization | Random | | |
| Cooling | Fan | | |
| Input power / Heat Load (Watts) | 580 | 580 | 720 |
| Input Voltage, Current | 48V / 12A | 48V / 12A | 48V / 15A |
| Frequency Range (kHz) | 0.1 - 140 kHz | | |
| Operating Temperature °C (°F) | 5 - 40 (40 - 104) | | |
| Operating Humidity | Non-Condensing | | |
| Shipping Temperature °C (°F) | -10 - 60 (14 - 140) | | |
| Weight (kg / lbs.) | 9 / 20 | | |
| Dimensions L x W x H (mm) | 323.8 x 174.0 x 138.4 | | |

*Power Stability is measured after 5 minutes warmup.
Specifications are typical and subject to change without notice

FEATURES & BENEFITS

- Patented Ceramic Core Design - excellent beam quality
- Aluminum Oxide Ceramic - no leakage or metal contamination
- Low Thermal Expansion - enhanced power and beam pointing stability
- Expanded Power Stability - consistent from 2% to maximum power
- 30% Fewer Laser Components - higher reliability
- Good Pulsing Characteristics – short rise and fall times
- Fast Driver Electronics - single-chip design, reliable, efficient and state of the art

APPLICATIONS

- Cutting/perforating
- Marking/coding
- Engraving/etching
- Wire Stripping
- Fiber optic splicing
- Medical surgery

Troubleshooting

| Problem | Solution |
|---|--|
| The unit is in the Ready mode but will not respond to commands. | <ul style="list-style-type: none"> • The Interlock Switch is open. • Mod LOW is not properly grounded. |
| The Over Temp Light lights. | <ul style="list-style-type: none"> • The RFPA heat sink is too hot for operation. • Above 55°C, a warning will also occur. • Improve cooling. • Check for intake blockage. |
| Laser power seems low. | <ul style="list-style-type: none"> • Operating temperature is very high. • The fan(s) have failed. • The heatsink is clogged with dust. • Optical damage to lens. • RFPA malfunction. |
| Fault light is lit. | <ul style="list-style-type: none"> • The laser is too hot. • Above 65°C, a Fault will also occur. • The DC voltage is outside the proper range. |

Indicator Lights Details

The following chart is provided for clarity:

| | | | | |
|------------------------|----------|----------|----------|----------|
| RED FAULT | off | on | on | blink |
| YELLOW WARN | on | on | off | off |
| Condition: | A | B | C | D |

- A = Getting hot warning, but no-fault condition.
- B = System faults: too hot/water too hot.
- C = System fault: over/under voltage, other faults.
- D = CPLD failure

Note: A blinking red light is the same level of fault as a solid red light.

